

PREMIUM PM

Automatic horizontal sliding car door
EN 81-20 compliance



Residencial



Commercial



Service lifts



Door configuration









LIFT APPLICATION

Door cycles per year:	Up to 1.500.000.
Traffic peak of the door:	Up to 360 cycles per hour.
Traffic lift speed:	Up to 6 m/s.

APPLICATION RANGE





Opening	Clear opening - CO (mm)	Clear height - CH (mm)
C2	650 - 2400	1800 - 3500
C4	700 - 3000	
C6	1600 - 3000	
T1	600 - 1200	
T2	700 - 1600	
T3	700 - 2000	

PANELS

Opening	Steel panels				Glass panels				
	Metal sheet ⁽¹⁾	Double skin	Vision	Wien type vision	Bevel big vision	Flush big vision	Full glass	Full glass hidden trims	Aluminium glass
									
C2 - C4 - C6 T1 - T2 - T3	✓	✓	✗	✓	✓	✓	✓	✓	✓

⁽¹⁾Solid execution option.

SILLS

Type of sill	Aluminium sill	Reinforced aluminium sill	Steel sill	Massive sill
Profile detail				
Availability	✓	✓	✓	✓
Heated sill option	✓	✓	✓	✗
Dust holes	✓	✓	✓	✓
Sill support	✓	✓	✓	✓

STANDARDS

Opening	EN 81-21 Existing buildings	EN 81-41 Impaired mobility	EN 81-71 Vandal resistance lifts		EN 81-72 Firefighters lifts
			Cat. I	Cat. II	
C2 - C4 - C6 T1 - T2 - T3	✓	☎	✓	✓	✓

PROTECTION

Opening	IP21 Protection against a solid foreign body of 12.5 mm or more in diameter and protected against vertically falling drops of water.	IPX3 Protected against sprays of water up to 60 degrees from the vertical.	IP54 Protection against dust and protected against water splashed from all directions.		IP65 Sealed against dust and protected against jets of water from all directions.	EEx Explosion proof, Group II (surface industries) and Category 2 (explosive atmosphere between 10 and 1000 hrs/yr).
			Magnetic contact	Mechanical contact		
C2 - C4 - C6 T1 - T2 - T3	✓	✓	✓	☎	☎	☎

Available
 ✗ Not available
 ☎ Ask to commercial department

Door configuration

SAFETY DEVICES

Opening	Photocell	Photoelectric barrier	Emergency power supply		Battery	
			VVVF5	VVVF6	VVVF5	VVVF6
C2 - C4 - C6 T1 - T2 - T3	✓	✓	✓	✗	✓	✗

PANEL REGULATION SUPPORT AND PANEL GUIDE

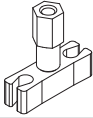
Type of panel regulation support	Plus	
Type of panel guide	Plus	

COMPATIBILITY

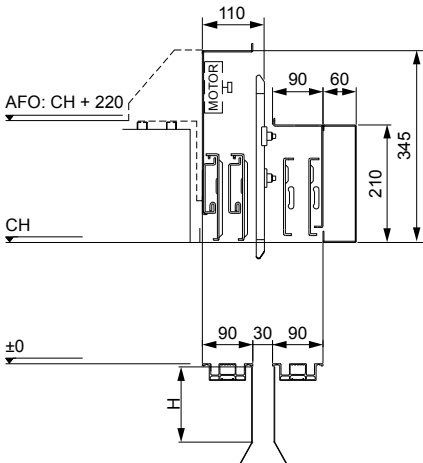

Case	40/10 Landing door
Coupling	Symmetric skate
Unlocking zone	+114 / -169
<small>T2 opening shown. All dimensions in mm.</small>	

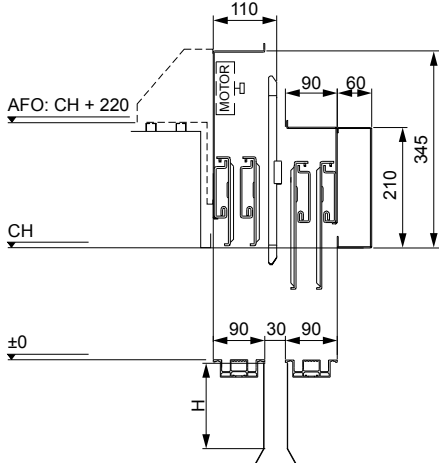



Case	Premium Landing door
Coupling	Asymmetric skate
Unlocking zone	+102 / -148
<small>T2 opening shown. All dimensions in mm.</small>	

Toe guard			
Type	Big	2 section	3 section
H*	750	795 (480)	780 (385)
Thickness	1.5		
Range	All	650 - 1200	
<small>*Contracted toe guard dimension between brackets. All dimensions in mm.</small>			

Toe guard			
Type	Big	2 section	3 section
H*	750	795 (480)	780 (385)
Thickness	1.5		
Range	All	650 - 1200	
<small>*Contracted toe guard dimension between brackets. All dimensions in mm.</small>			

CAMS

Compatibility	Semiautomatic hinged landing door: Aluminium, Global, Fermator, B+		
Type of cam	Inverted retractable	Flexible fixed	Fixed
Drawing			

✓ Available

✗ Not available

☎ Ask to commercial department

Technical features



DRIVE

Type	Synchronous brushless permanent magnets motor.	
Efficiency	80%.	
Consumptions	Standby 4 W / Average per cycle 20 W.	

Transmission	Gearless*	CO 700 - 1400 mm.	Eagle belt.
	Geared.	CO > 1400 mm.	RPP5 belt.

*Geared antibanging system available.

ELECTRONIC MODULE

Type	VVVF5 and VVVF6.
Adjustable parameters via	PC / Console / Smartphone.
Working signals available	From 12 V to 240 V AC/DC or with BUS CAN.
Opening speed	Up to 1 m/s (Regulable).
Closing speed	Up to 0.6 m/s. Auto-adjustable directly with the panel weight.
Re-opening	Integrated with auto-adjustable cycles.

GENERAL FEATURES

Noise level	< 48 dB.
Total weight	Reference: T2 CO 800 mm CH 2000 mm, with metal sheet panels - 68 kg.
Maximum moving mass	360 kg.
Locking device	Available car door lock type.

INSTALLATION

Pre-adjusted and tested to simplify the installation.
Frontal concept, all parts within the sill projection, allows fixing directly to the front or by regulable range of brackets.

Technical drawing 2 panel centre parting door

54 mm sill

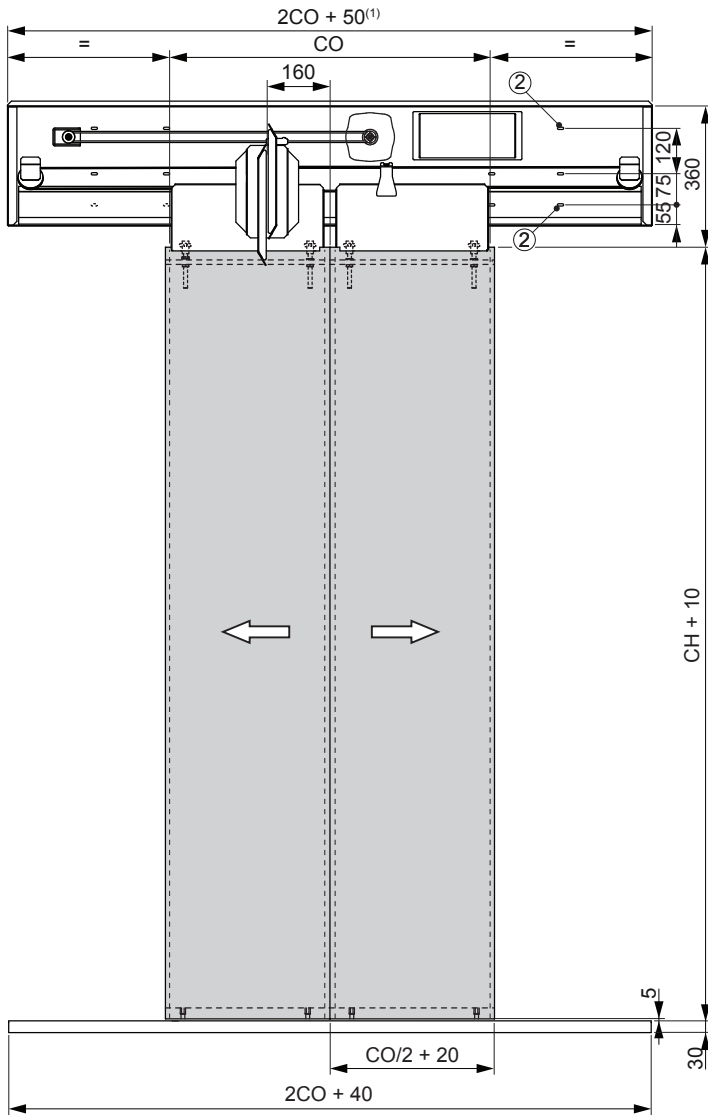

FIXING BRACKETS RANGE

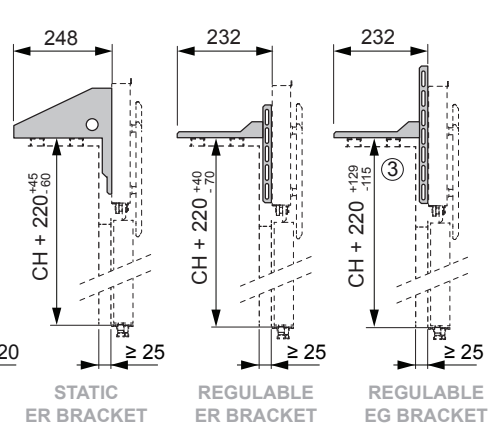

MECHANICAL DETAILS

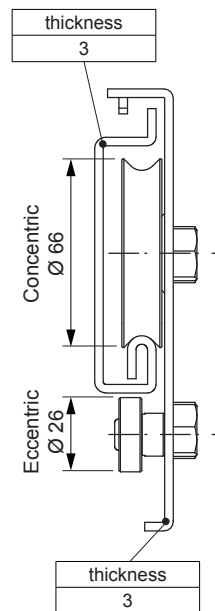

SILL DETAIL

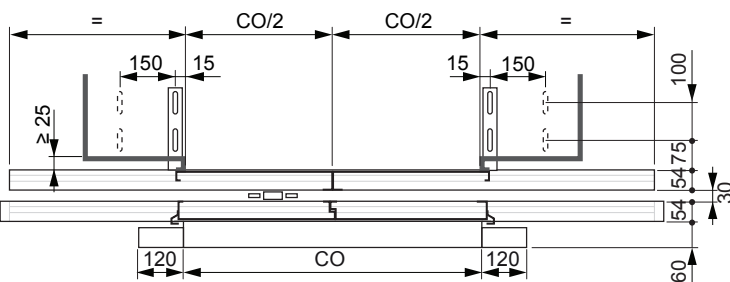
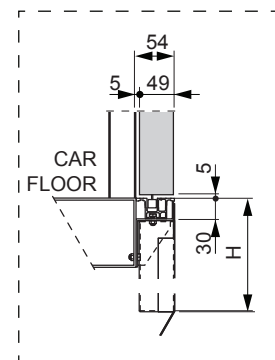

Notes:

- For CO 650 this dimension is 1346.
 - Recommended fixing point in vertical for each bracket.
 - In cases of extreme lower regulation, we recommend to add an extra fixing point to the car front.
- All dimensions in mm.

Technical drawing 4 panel centre parting door

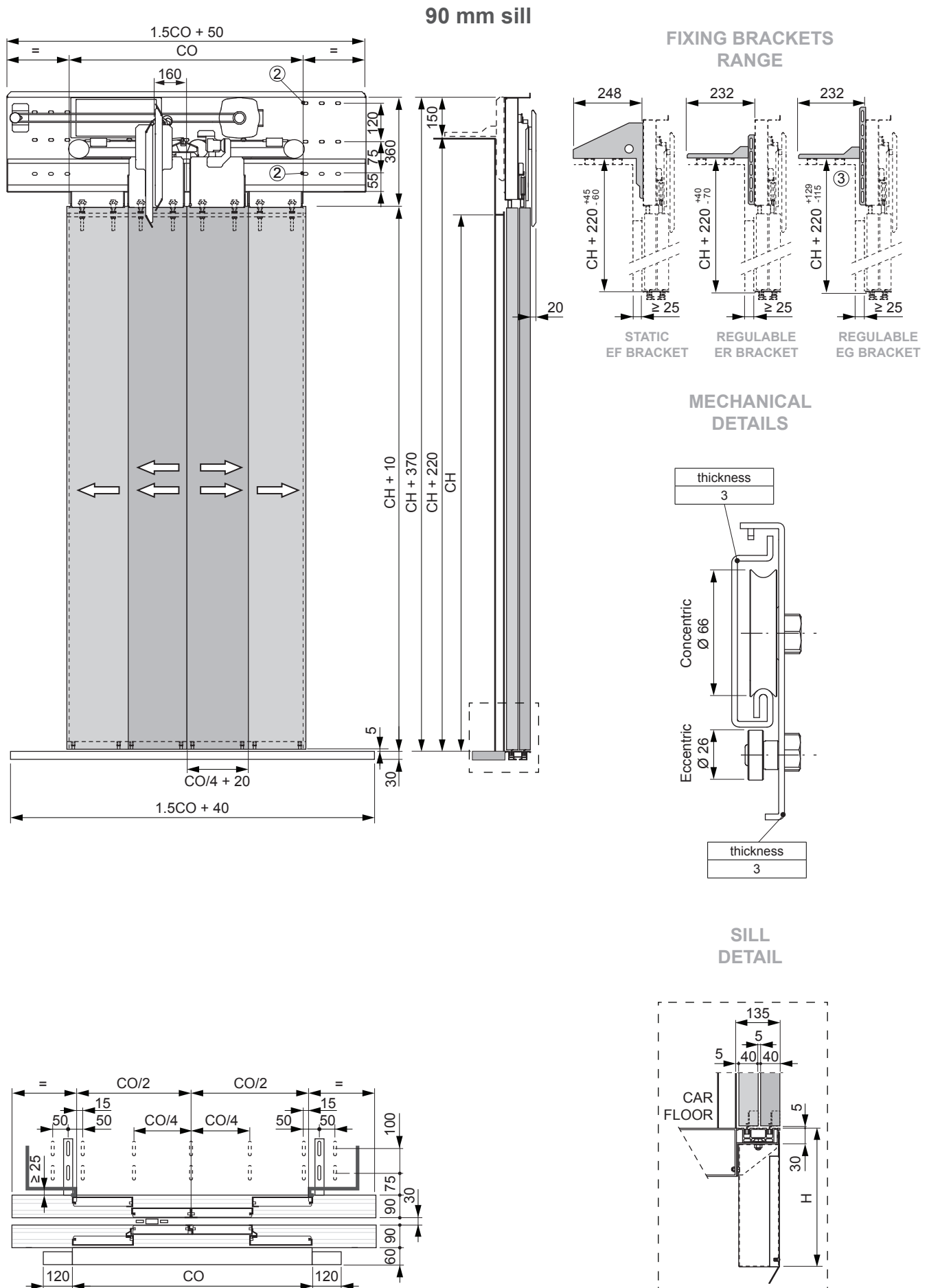

Technical drawing 6 panel centre parting door

135 mm sill

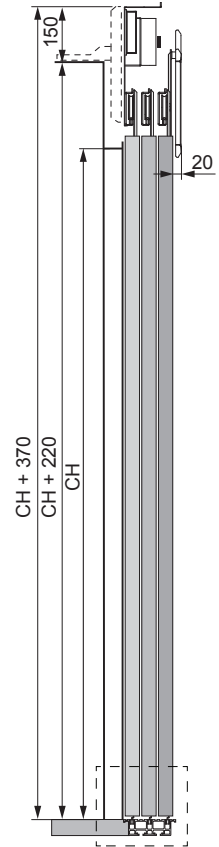
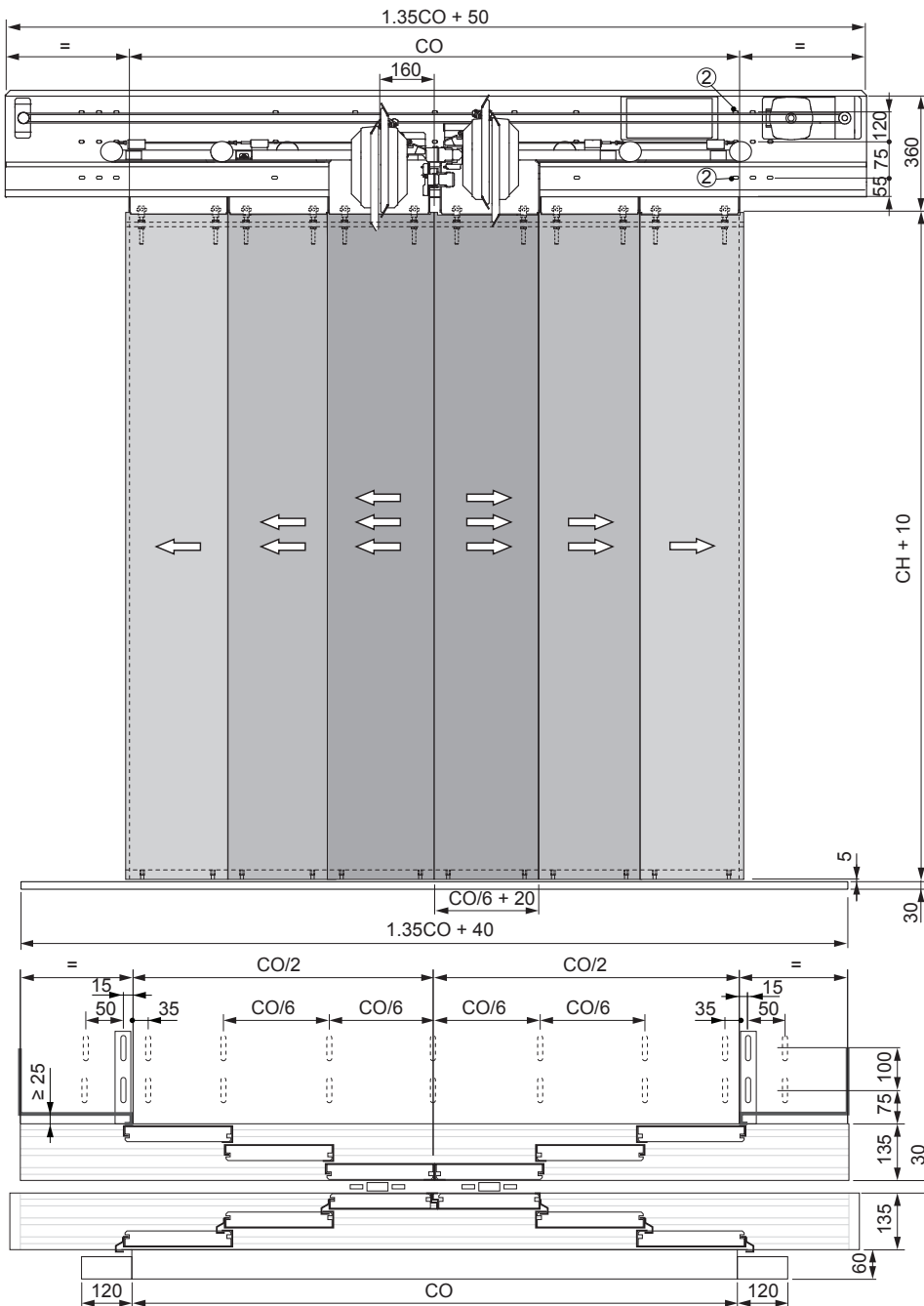

FIXING BRACKETS RANGE

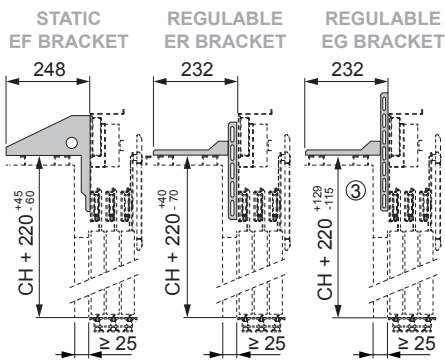

MECHANICAL DETAILS

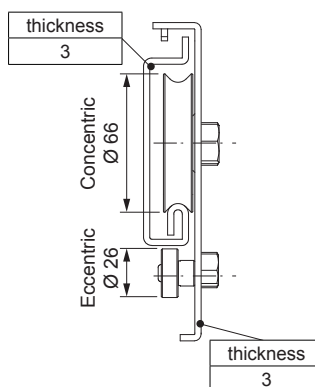

SILL DETAIL

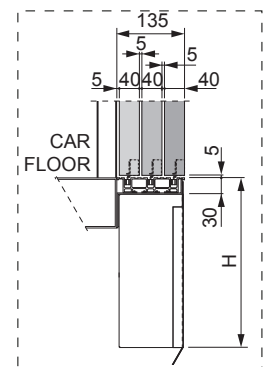

Notes:

- 2 Recommended fixing point in vertical for each bracket.
 - 3 In cases of extreme lower regulation, we recommend to add an extra fixing point to the car front.
- All dimensions in mm.

Technical drawing 1 panel side opening door

54 mm sill

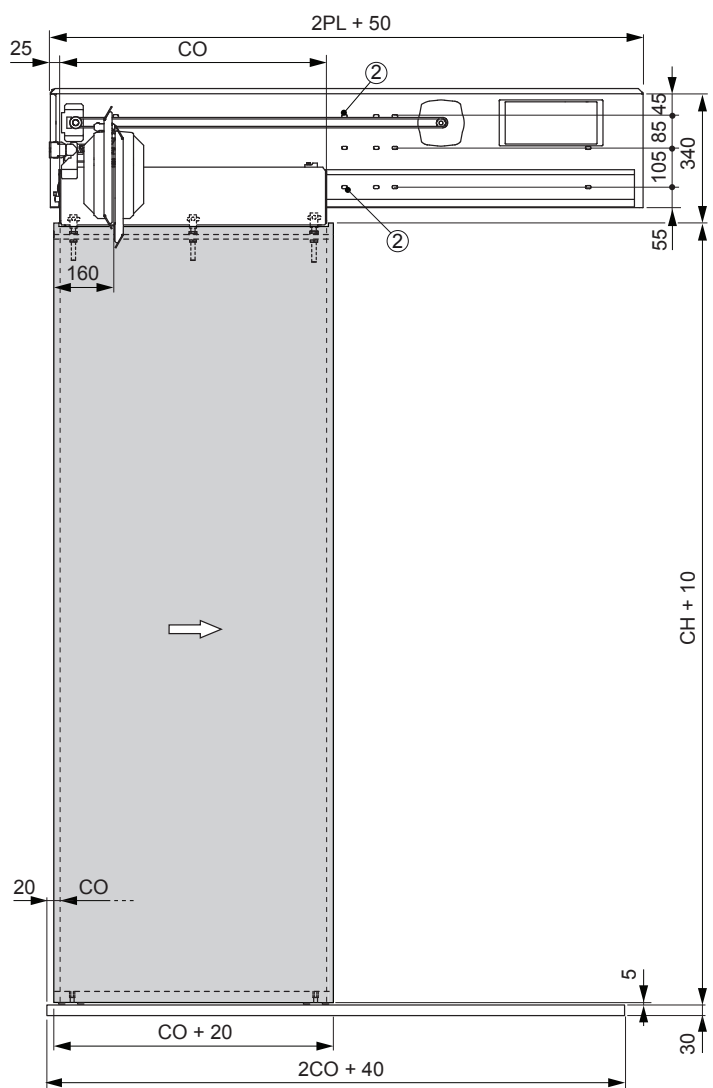

FIXING BRACKETS RANGE

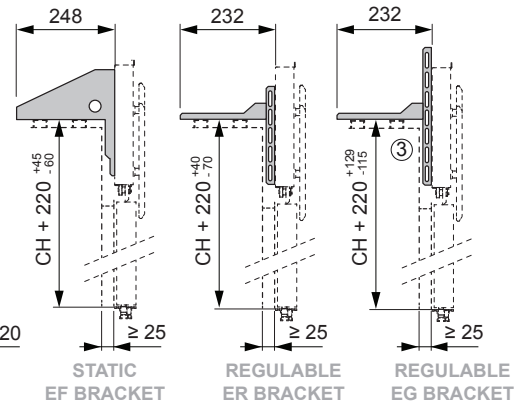

MECHANICAL DETAILS

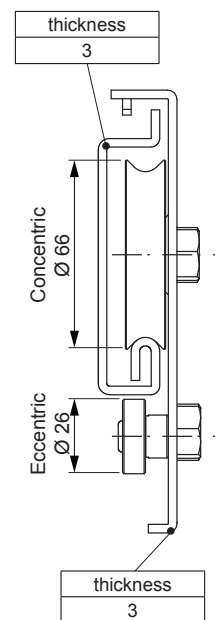

SILL DETAIL

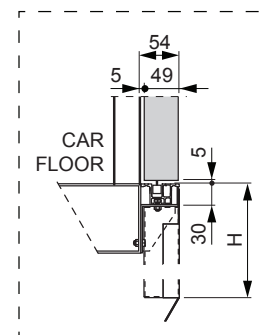
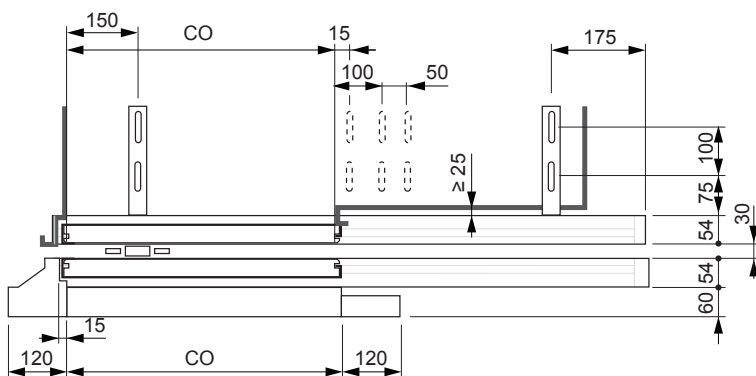

Notes:

- 2 Recommended fixing point in vertical for each bracket.
 - 3 In cases of extreme lower regulation, we recommend to add an extra fixing point to the car front.
- All dimensions in mm.

Technical drawing 2 panel side opening door

90 mm sill

FIXING BRACKETS RANGE

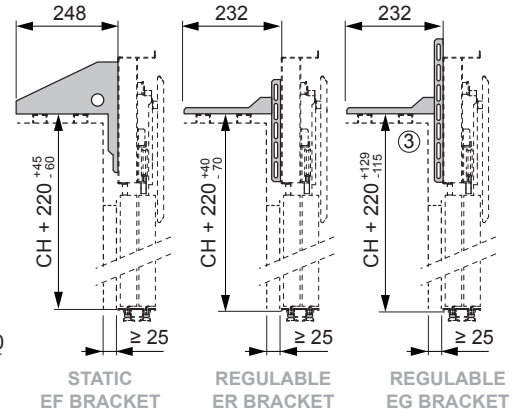

MECHANICAL DETAILS

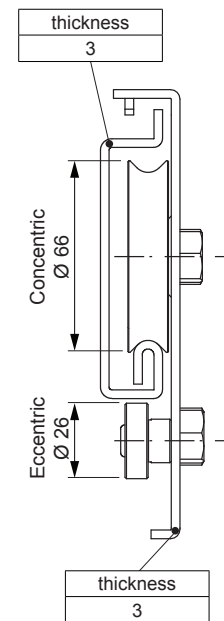

SILL DETAIL

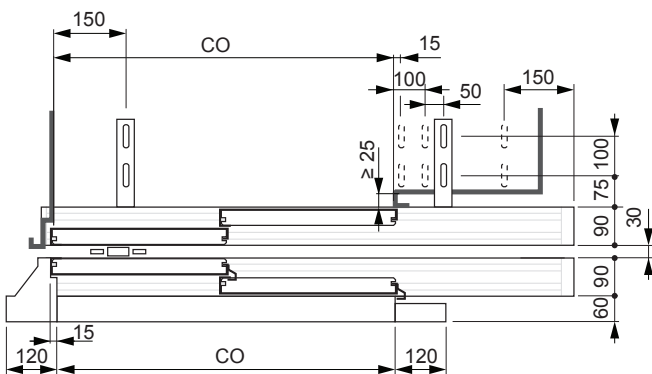
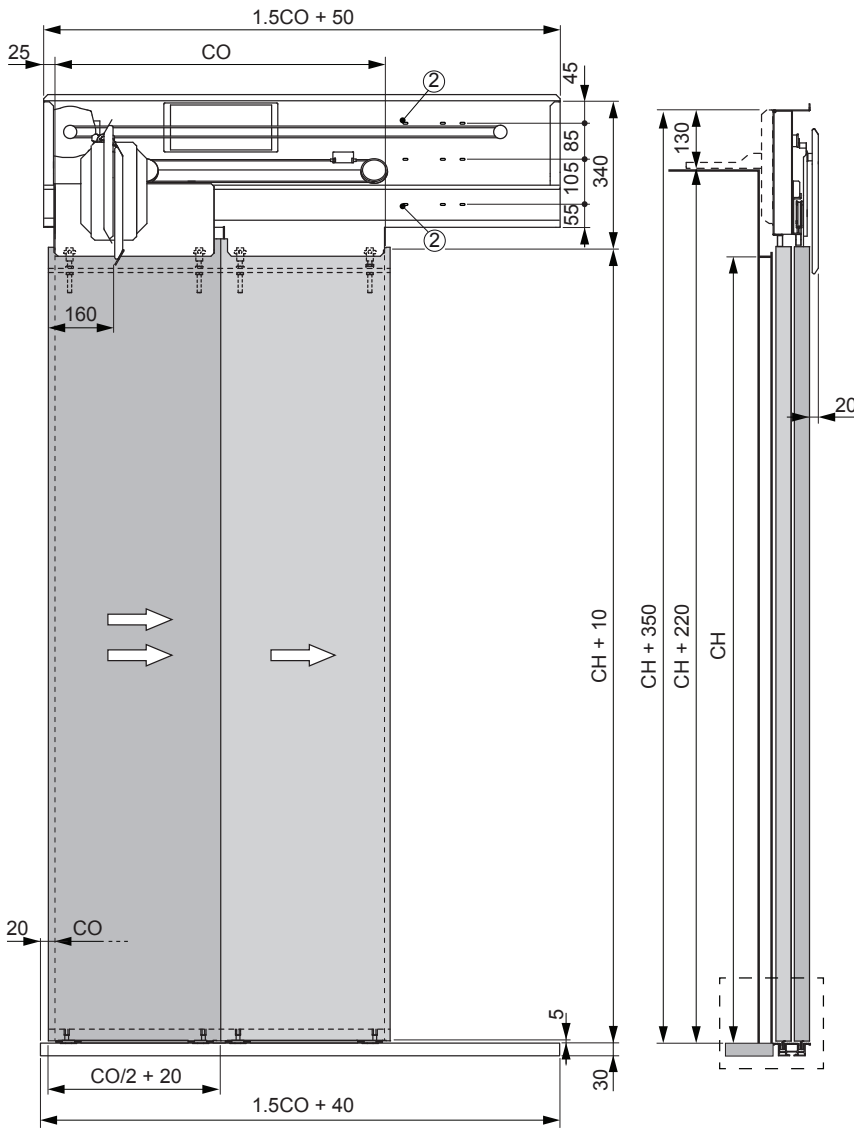
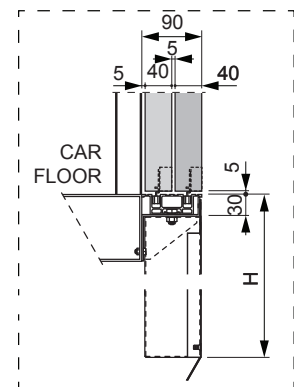

Notes:

- 2 Recommended fixing point in vertical for each bracket.
 - 3 In cases of extreme lower regulation, we recommend to add an extra fixing point to the car front.
- All dimensions in mm.

Technical drawing 3 panel side opening door

135 mm sill

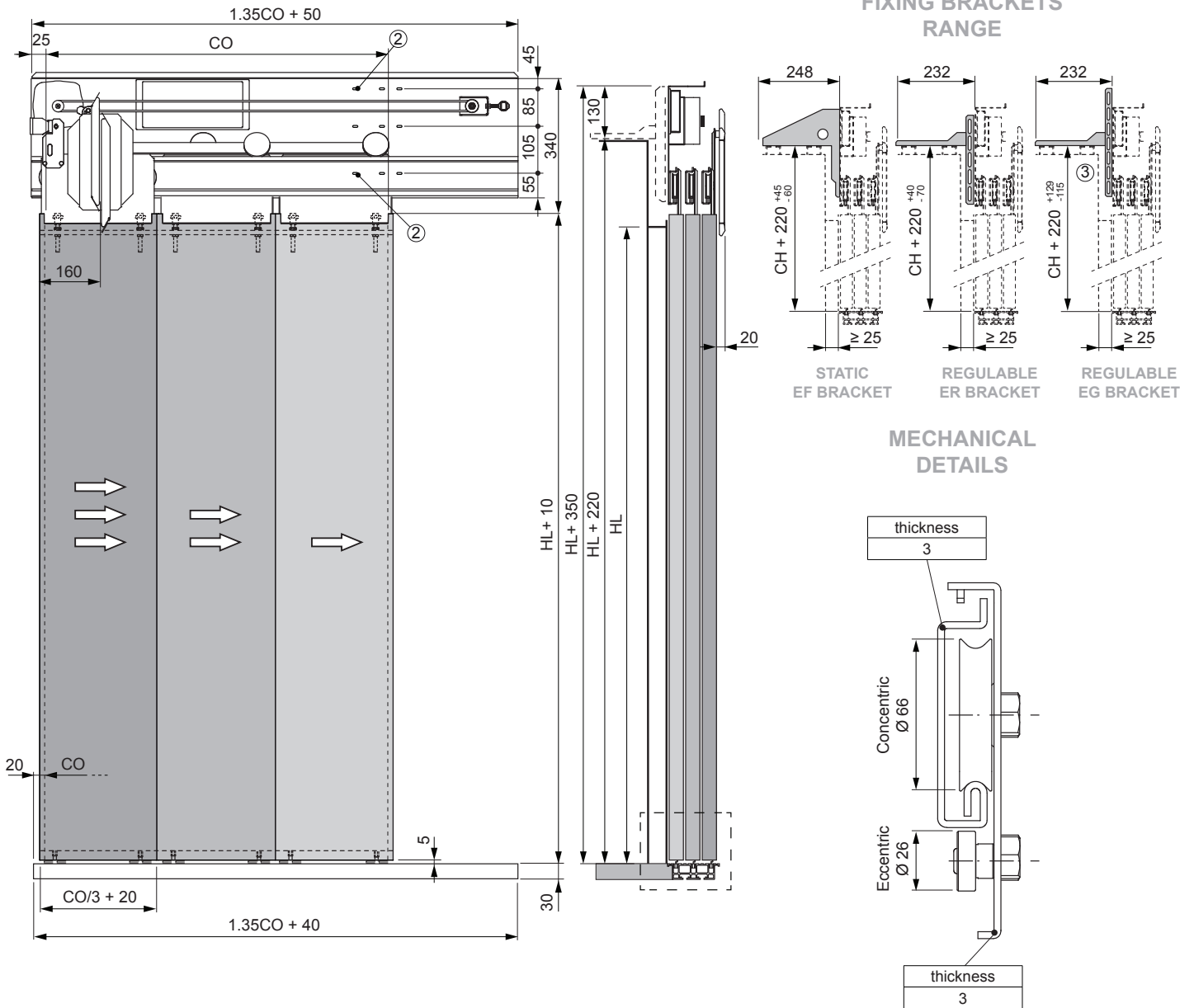

Notes:

- 2 Recommended fixing point in vertical for each bracket.
- 3 In cases of extreme lower regulation, we recommend to add an extra fixing point to the car front.
- All dimensions in mm.



Sales contacts

Spain: commercial@es.fermator.com • Italy: commercial@it.fermator.com • France: commercial@fr.fermator.com • Brazil: commercial@br.fermator.com
China: commercial@cn.fermator.com • India: commercial@in.fermator.com • Poland: commercial@pl.fermator.com

www.fermator.com